

PV ENERGY STORAGE SYSTEM

LiFePO₄ Battery Pack



BCT-V-24-250

24V-250Ah

APPLICABLE PLACE

COMPREHENSIVE ENERGY SUPPLY

For no city power areas, the battery pack can be charged by solar panels and used for night lighting; For the areas that city power is expensive, the battery pack can be charged during the electricity valley value period, and used at the peak power period; For the areas which power off from time to time, the battery pack can be used as UPS, to avoid information loss caused by sudden power outage. The battery pack is applicable to commercial lighting, industrial lighting, home lighting, outdoor lighting, camping tourism, farming, planting, the night market stalls, etc.

Blue Carbon



Daytime solar power generation
Cover daytime electricity

Night energy storage discharge
Cover power consumption at night

- ▶ Storing the power from the solar panel, to be used as reserve power or emergency power supply.
- ▶ At night or at the time of power outage, it can supply the power to electrical appliances by using the stored energy, to avoid the inconvenience caused by power outage, so that you can calmly deal with the situation of power outages.

Technical Parameters

Model: **BCT-V-24-250**

Model	BCT-V-24-250		Battery	Cell Type	LiFePO ₄ Battery/LFP
Basic Specifications	Nominal Capacity	250Ah		Storage Temperature Range	Short-Term -20°C-40°C(Within 1 month)
	Nominal Voltage	24V(25.6V)			Long-term 10°C-35°C(Within 1 year)
	Electricity(kWh)	6.4kWh		Operating Temperature Range	-15°C-60°C
Input	Full charge Voltage	29.2V		Recommended Temperature range	10°C-40°C
	Maximum Charging Voltage	30V		Storage Humidity	≤75% RH
	Input Voltage Range	28V-30V		Atmospheric Pressure	Below the elevation of 5000m
	Continuously Use Input Current	100A		Self-Discharge (25°)	< 3%/Month
	Maximum Solar Panel Input Current	100A		Depth of Discharge	> 80%
	Rshoot Delay Protection	1000ms		C-rate Discharge	< 0.8C
Output	Continuously Use Output Current	100A	Other	Certification Standards	UN38.3/CE/MSDS/DGM
	Discharge Cut-off Voltage	20V-24V		Product Size	614±2mm×507±2mm×212±2mm
	Over-Discharge Delay Protection	1000ms		Packing Size	668±2mm×328±2mm×706±2mm
	Short Circuit Protection Delay	300us			
	Short Circuit Protection Recovery	Disconnect load			
	Instant Start Current	400A			
	Instant Start Current Time	10S			

PRODUCT SIZE

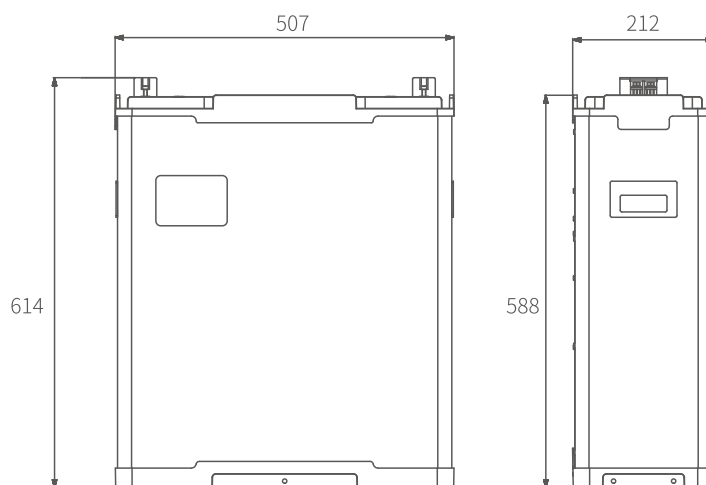

Unit: mm

PRODUCT ADVANTAGES

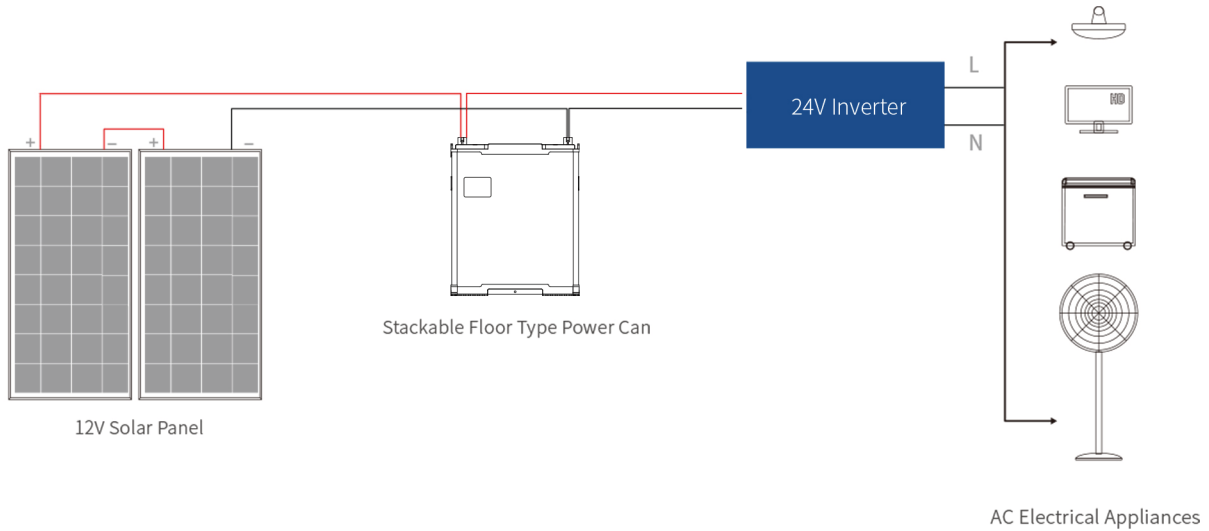

- All in one mould design and production, easy to install.
- With longer span life LiFePO4 battery, over 12 years lifespan, ensure the whole set products' life span.
- Dustproof structure design, DC output, safe and reliable.
- Integrated packaging, safe and convenient to transport.
- Wide voltage input, when unexpected high voltage input, can effectively block the high voltage, so that the BMS of the battery will not be broken down, greatly reducing the risk of thermal runaway combustion of lithium battery.
- Compact appearance design, extremely compressed product thickness, greatly reducing space occupancy.
- High quality aluminium magnesium alloy, anti-corrosion, substantial, durable, artistic, practical.
- Integrated charging and storage, reduce wiring, installation and other work, and facilitate user operation.

● Military Aviation Plug

Never oxidize in high temperature, high humidity and high-salt environment; No risk of thermal runaway and fire



● Split-type Building Block Design

Buckle design, which can increase the capacity by alignment and stacking; Firmly fixed and can be carried by single person



● Rubber Feet Pad

The bottom of battery is equipped with rubber feet pad to increase safety and play roles of shock-proof buffer, anti-static, electrical insulation and so on.

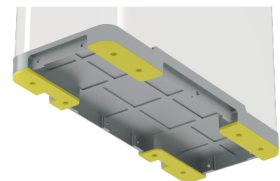

Blue Carbon

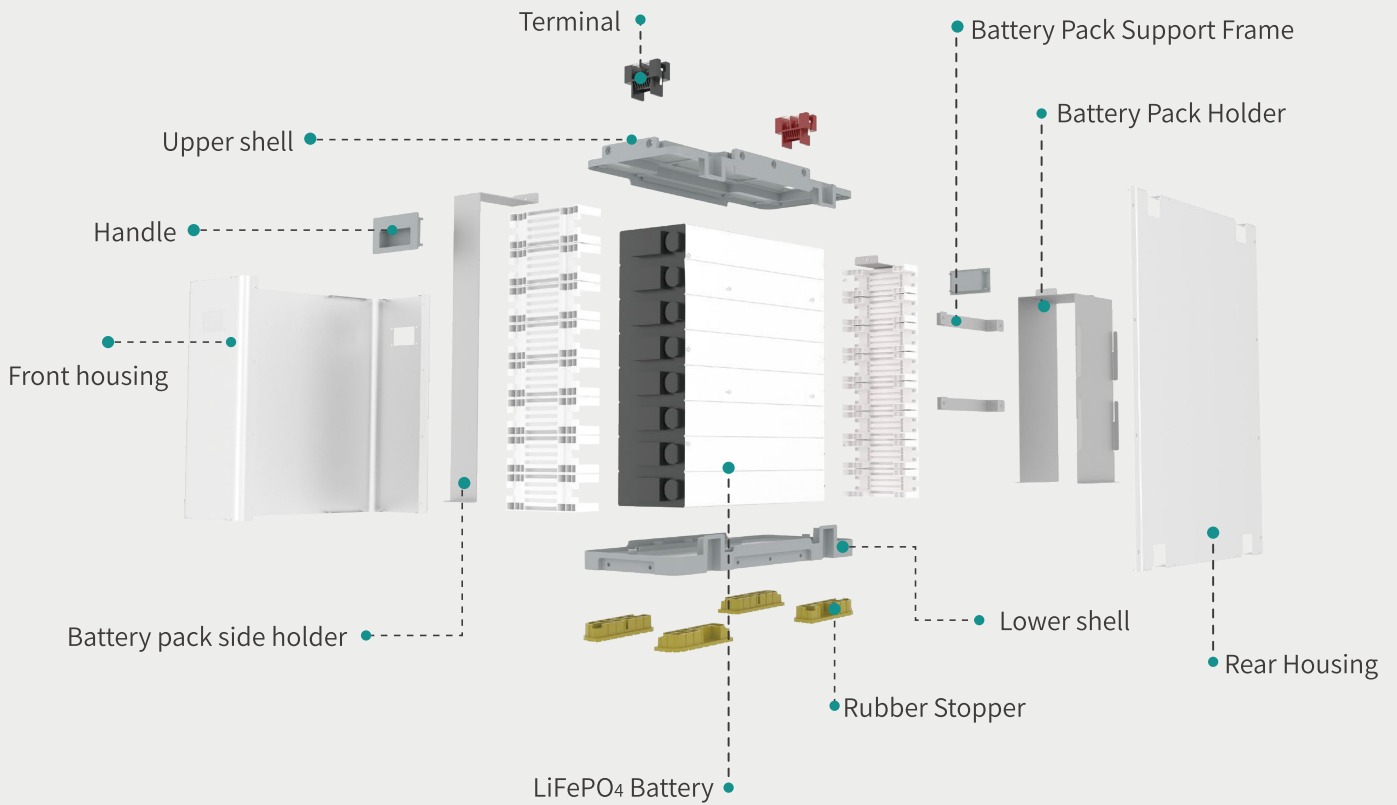

Store your electric energy to cope with the evening peak or power outage.



More Available Power



Flexible Investment



Simple Installation



Safe & Reliable

matters need attention:

- It is strictly forbidden to install near bedroom and nearby flammable material.
- Installation in inhabited rooms is not recommended.
- It is strictly forbidden to use the controllers, inverters, inverters and controller integrated equipment which are not professionally matched.

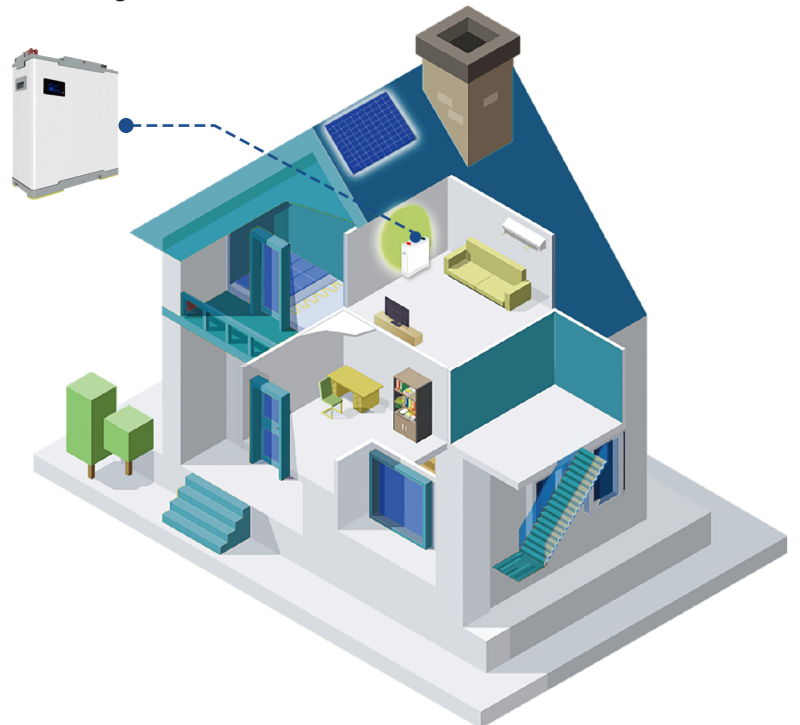

+86-0633-2190373 <https://www.bluecarbontech.com.cn/en/>

Office Location
Building A, International Fortune Center, Rizhao City, Shandong Province, China

BLUE CARBON TECHNOLOGY INC.

Photovoltaic Generation-Storage-Application System Supplier

Blue Carbon



Solar Energy

Using sunlight to achieve clean energy charging can supply power to household appliances.



Storing Energy

Realize the freedom of electricity consumption in the area where there is no electricity and less electricity.



Household

Free electricity.

Store your electric energy to cope with the evening peak or power outage.



+86-0633-2190373 <https://www.bluecarbontech.com.cn/en/>

Office Location
Building A, International Fortune Center, Rizhao City, Shandong Province, China

BLUE CARBON TECHNOLOGY INC.

Photovoltaic Generation-Storage-Application System Supplier

Blue Carbon

BATTERY SPECIFICATION

Different Rate Discharge Curve (25°C)

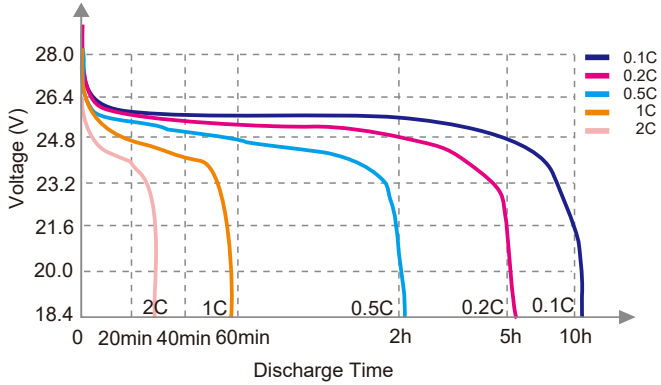

Different Temperature Discharge Curve (0.5C)

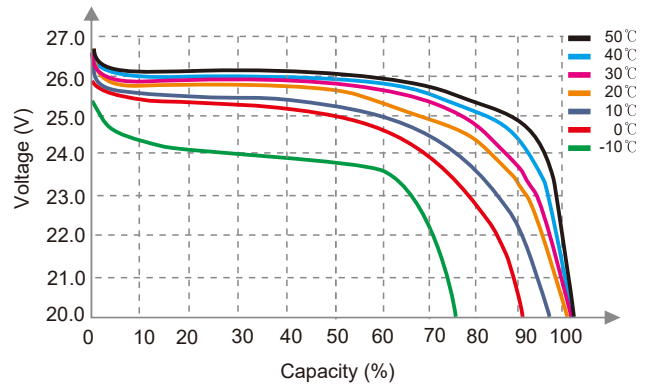

State of Charge Curve (0.5C, 25°C)

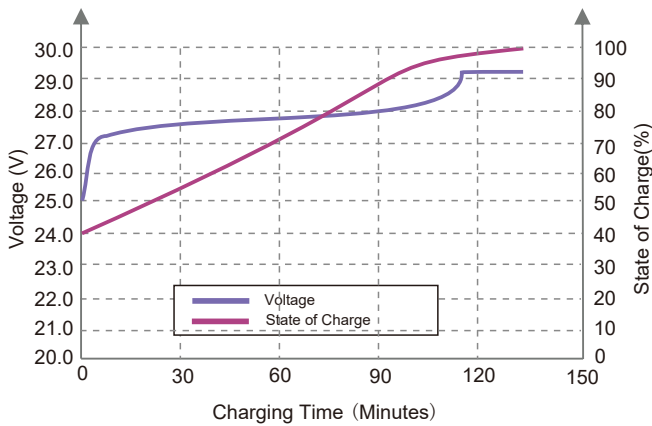

Charging Characteristics (0.5C, 25°C)

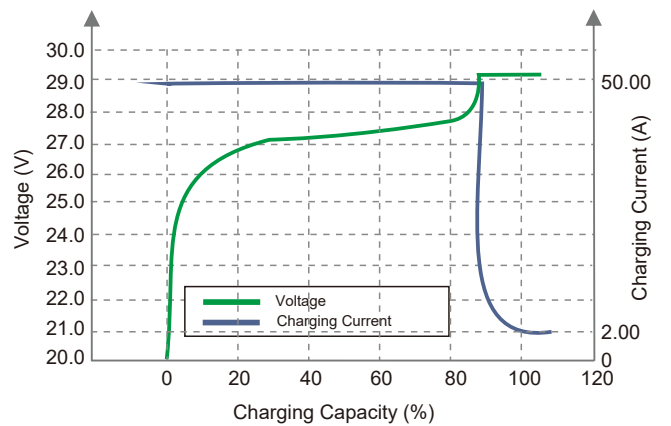

Different Temperature Self Discharge Curve

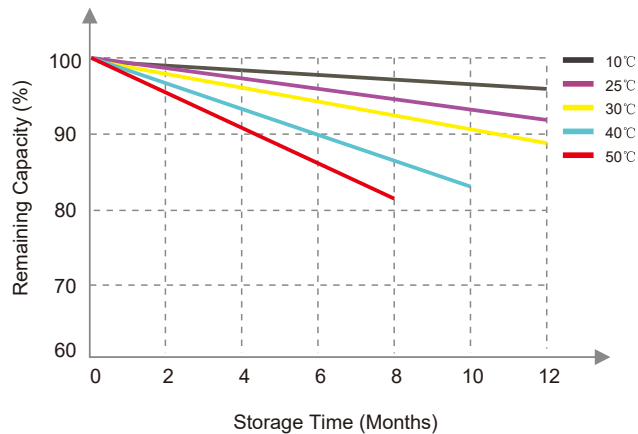

Blue Carbon



6.4kWh Stackable Floor Type Power Can LiFePO₄ Battery Pack

System Configuration

- 6.4kWh LiFePO₄ Battery Pack
- Solar Panel
- Solar Controller

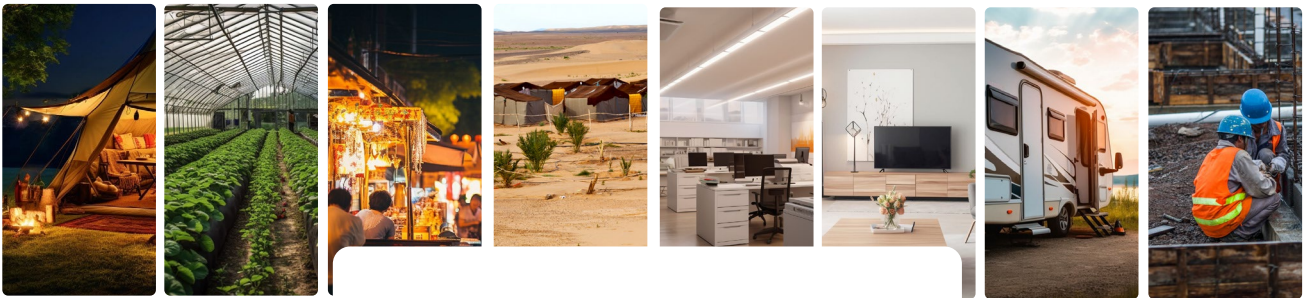

Suitable for Various Scenes

Friendly man-machine Combination

Smart and Reliable
Scalable and Flexible



+86-0633-2190373 <https://www.bluecarbontech.com.cn/en/>

Office Location
Building A, International Fortune Center, Rizhao City, Shandong Province, China

BLUE CARBON TECHNOLOGY INC.

Photovoltaic Generation-Storage-Application System Supplier